



Section 8



Table of Contents

8	STREETLIGHTING	1
8.1	General Requirements.....	1
8.2	Design Criteria.....	1
8.2.1	Within Public ROW.....	1
8.2.2	Site Plans.....	4
8.2.3	Lighting Configurations and Pole Offsets.....	5
8.2.4	Installation.....	5
8.2.5	Materials.....	6

List of Tables

Table 1. Maintained Luminance for Mid-Block Street Sections (Non-Intersection Areas)

Table 2: Maintained Luminance for Street Corridors near Intersections, Curvilinear Sections and Pedestrian Walkways/Bikeways Table 3. Tree Protection Zones

Table 3. Streetlighting Material List

8 STREETLIGHTING

8.1 General Requirements

All roadways are to be lit, unless written approval is received from the Town. Streetlights shall be provided throughout all developments and may be required on roadways bordering developments if deemed necessary by the Town.

A qualified engineering consultant shall prepare the streetlight design, including photometric layouts using an approved computer lighting program such as AGI 32, AutoLux, or equivalent.

All drawings must be sealed by a registered electrical Professional Engineer, licensed to practice in the Province of Ontario. Any attachments to hydro poles must have Hydro Authority approval and comply with Regulation 22/04 (or the latest revision thereof). All roadway lighting design and construction is subject to Electrical Safety Authority (ESA) inspection and approval.

The Transportation Association of Canada (TAC) “Guide for Design of Roadway Lighting”, Volumes 1 and 2 provide comprehensive design guidelines and may be used for lighting devices for roadways and associated facilities.

8.2 Design Criteria

8.2.1 Within Public ROW

Lighting design criteria for roadways, sidewalks, pedestrian walkways, and bikeways on public right-of-ways within the Town of Tillsonburg shall be based on the “American National Standard Practice for Roadway Lighting”, ANSI/IESNA RP-8-14, or the latest revision thereof.

The lighting system shall provide the average maintained light levels and meet the recommended uniformities and veiling luminance ratios as indicated in Table 4 and 5.

“Luminance” criteria may be used for determining light levels on straight and level roads that have a minimum length of ten (10) luminaire mounting heights.

“Illuminance” criteria to be used for intersections, curvilinear road sections, pedestrian walkways, and bikeways.

The design criteria requirements for luminance, illuminance, and pedestrian conflict area classifications in Tables 1 and 2 are derived from ANSI/IES RP-8-14.

The criteria listed in Table 2, for intersections, is to be applied to cover the thirty-two (32) conflict points identified in ANSI/IES RP-8-14 (se. 5.1.2). The criteria listed in Table 4 would apply outside of this.

Local roads within new subdivisions will use black coated Standard Roadway Luminaires: LED – Decorative light poles and fixtures unless expansion of existing subdivision and transition from existing pole and fixture colour and type cannot occur; to be approved by Town staff.

Table 1. Maintained Luminance for Mid-Block Street Sections (Non-Intersection Areas)

Road Classification	Minimum Average Maintained Luminance L_{avg} (cd/m ²)	Maximum Uniformity Ratio L_{max} to L_{min}	Maximum Luminance Ratio L_{avg} to L_{min}	Maximum Veiling Luminance Ratio L_v to L_{avg}	Pedestrian Conflict Area Classification
Arterial/Major Roads	0.6	6.0 to 1	3.5 to 1	0.3 to 1	Low
Arterial/Major Roads	0.9	5.0 to 1	3.0 to 1	0.3 to 1	Medium
Collector Roads (Minor)	0.4	8.0 to 1	4.0 to 1	0.4 to 1	Low
Collector Roads (Major)	0.6	6.0 to 1	3.5 to 1	0.4 to 1	Medium
Local Roads (Rural)	0.3	10.0 to 1	6.0 to 1	0.4 to 1	Low
Local Roads	0.5	10.0 to 1	6.0 to 1	0.4 to 1	Medium

Table 2. Maintained Luminance for Street Corridors near Intersections, Curvilinear Sections and Pedestrian Walkways/Bikeways

Maintained Illuminations for Roadways near Intersections and Curvilinear Sections		
Road and Pedestrian Conflict Area Classification	Minimum Average Maintained Illuminance (Horizontal Only) (R2 & R3 Pavements) E_{avg} (lux)	Maximum Illuminance Uniformity Ratio E_{avg} to E_{min}
Arterial/Major Roads - Low	9	3.0 to 1
Arterial/Major Roads - Medium	13	3.0 to 1
Collector Roads (Minor) - Low	6	4.0 to 1
Collector Roads (Major) - Medium	9	4.0 to 1
Local Roads (Rural) - Low	4	6.0 to 1
Local Roads (Urban/Industrial) - Medium	7	6.0 to 1

Maintained Illuminations for Pedestrian Walkways/Bikeways		
Road and Pedestrian Conflict Area Classification	Minimum Average Maintained Illuminance (Horizontal Only) (R2 & R3 Pavements) E_{avg} (lux)	Maximum Illuminance Uniformity Ratio E_{avg} to E_{min}
Rural and Semi - Rural Areas	2	10.0 to 1
Pedestrian Areas – Low (2 or fewer dwelling units per acre or 5 units per ha)	3	6.0 to 1
Pedestrian Areas – Medium (2.1 to 6 dwelling units per acre or 5.1 to 15 units per ha)	5	4.0 to 1

Intersections shall have an illumination level equal to the sum of the recommended average illumination levels for each of the intersecting roadways. If it is not practical to achieve this level due to geometric constraints, then a minimum level of 50% higher than the recommended level for the main roadway may be acceptable, subject to the Town’s approval. Alternatively, Town may request to follow Table 8 in ANSI/IES RP-8-14, or any update of this standard.

For illumination of crosswalks (mid-block or at intersections) refer to Section 5.3 of ANSI/IES RP-8-14.

Light levels shall be increased by 50% through school areas, libraries, recreation centres, medical centres, railway crossings, bridges and any other location where increased conflict is possible. The street lights shall typically be serviced with underground wiring in ducts between poles. The luminaires shall be alternated between circuits to maintain 50% illumination upon loss of one circuit feeder.

Light source for roadway lighting shall be long life (minimum 100,000 hours).

Power supply shall be coordinated and arranged with the Supply Authority from the nearest feasible location. Power supply shall be unmetered and the street lights shall operate at 120 volts 60 Hz AC. Maximum voltage drop at the end of the lighting circuit shall not exceed 5% of the supply voltage.

The design drawings shall show all surface features, all street light pole complete with ID#, all power pedestals complete with ID#, the individual conduits from the power pedestal to the light-emitting diode (LED) lights, the conduit from street light pole to street light pole, all utility road crossings with dimensions from the road crossing to either a side lot line or a street light pole, and dimensions from the street light pole to the lot lines where the street light pole is not opposite a side lot line. The LED street light ID# shall include the type of LED lighting fixture, the circuit number, and the power pedestal number to which it is connected. The Legend shall include duct sizes and an explanation of the street light symbol/ID#’s.

On the single line drawing, there should be an electrical schematic for each power pedestal showing the transformer (complete with Town ID#) that supplies power to the power pedestal, the power pedestal cabinet contents (service breakers, service panel, grounding rods, etc.), each circuit and all of the LED street lights (complete with ID#) connected to that circuit with conductor lengths from the pedestal to the first light and from light to light, and all electrical components inside the LED street light fixtures. It should be noted that the maximum conductor length is 100 m.

Lighting calculations shall be prepared for all outdoor site lighting and forwarded to the Municipality for approval.

All luminaires are to be provided with ANSI C136.41 compliant dimming photocontrol allowing at least three different settings for dimming levels and start times.

Refer to Table 3 for a list of materials and specifications.

Streetlight designer should contact Town and confirm full set of criteria before the start of design.

8.2.2 Site Plans

Lighting should be controlled by automatic switching devices such as timers or photocells.

Parking Lots

Parking lot illumination has to address good visibility for drivers and pedestrians, provide good colour rendition for security identification, and leave sufficient impact for customer attraction.

The recommended light levels for high activity community shopping developments are:

- Average maintained illuminance level 2.0 fc (20 lux) minimum. This could be increased up to 5.0 fc (50 lux), as is common practice for current commercial developments
- Uniformity, average to minimum 4:1

The minimum recommended light levels for parking lots are:

- Minimum horizontal illuminance level 0.2 fc (2 lux)
- Uniformity ratio, maximum to minimum 20:1

Roadways

The recommended light levels for the site roadway zones are:

- Average maintained illuminance level 0.9 fc (9.0 lux)
- Uniformity, average to minimum 6:1

Pedestrian Walkways

The recommended light levels for pedestrian walkways up to and surrounding any commercial buildings are:

- Average maintained illuminance level for medium activity areas 2.0 fc (20 lux) and high activity areas 4.0 fc (40 lux)
- Uniformity, average to minimum 4:1

Site Restriction

The recommended light levels projected onto a residential property (spill light) shall not exceed 0.1 vertical foot candles, measured line-of-site at the property line.

Pylon Signs

Externally illuminated pylon signs shall have the light source aimed downward towards the sign.

8.2.3 Lighting Configurations and Pole Offsets

All streets are to employ a staggered streetlight configuration with pole offsets from EP as per TAC criteria or on shoulder rounding.

In rural areas where TAC pole offsets outside the clear zone are not possible, frangible breakaway bases may be used. Frangible bases are not permitted at intersections and areas where pedestrians are expected.

Pole offsets that are identified on the Town's Typical Road Cross Sections take precedence.

Lights at signalized intersections should be combined with joint-use traffic signal poles wherever possible.

On curved roadways, the light poles should be positioned on the inside of curves, if possible. Alternatively, light poles may be placed on the outside of curves, but shall be kept out of the vehicle overrun area (the extension of the tangent in the direction of vehicle travel).

Street lights and power pedestals should be located on the extension side lot lines where possible.

8.2.4 Installation

The installation of the street lighting system shall be in compliance with ESA, CSA, the Hydro Supply Authority requirements, the Town's standards and specifications, as well as the manufacturer's installation instructions.

Ducts

Ducts shall be solvent welded together in trenches with minimum cover of 750 mm. Ducts shall be surrounded by 80 mm of brick sand and warning tape to cover width of trench.

Road crossings to be carried out by directional bore method using thickwall PVC duct.

Where open-cut road crossings are necessary, ducts shall be concrete encased.

Installation as per OPSD 2100.06, 2103.02 and OPSS 603.

Cables

Cables to be continuous without splices and shall be installed after trenches are back-filled.

Installation Specifications as per OPSS 604.

Fuses

Fuses in pole handholes as per OPSD 2255.020 and OPSS 617.

Grounding

Ground rods to be installed at power service disconnect (minimum 2 rods), at every fifth (5th) lighting pole, and at the last lighting pole in each circuit.

Installation Specifications as per OPSS 609.

Poles

Installation Specifications as per OPSS 615.

Brackets and Luminaires

Installation Specifications as per OPSS 617.

Power Service Disconnect

Installation Specifications as per OPSS 614.

Dimming control

Specifications as per ANSI C136.41. DIM-4 adjustable control.

8.2.5 Materials

All materials used for street lighting must be CSA approved. Refer to Table 3 for a list of Materials and Specifications.

Table 3. Streetlighting Material List

Material	Standards	Features	Manufacturer	Catalogue No.
1.0 Lighting				
Electrical Handholes	CSA	Precast concrete type complete with cover, 460mm Dia., as per OPSD 2112.02.		
Ducts	CSA C22.2, No.211.1 CSA C22.2, No.211.2 CSA Standard B137.1, Series 75 or ENT CSA C22.2, No.227.1	In boulevard, rigid PVC DB2 duct, 53mm Dia. Below roadways, rigid PVC Thickwall duct, 53mm Dia. Flexible duct (Polypipe) to be used for protection of cables entering the wiring aperture in the concrete poles.		
Cables	CSA C22.2 No.38	Power supply cables shall be 3-#2 AWG copper RWU90 (including ground wire), with cross- linked polyethylene insulation rated 600 volt. Street light cables shall be 1-2C#6AWG copper and #10 AWG copper GND, 60°C, NMWU; or 2-#6 AWG copper RW90 and #8AWG copper GND RW90 Riser wires from pole handhole to luminaire shall be #12 AWG stranded copper type RWU90 insulation. Insulation colour for line conductors for 1-phase, 3-wire 240/120V system shall be "Red" and "Black" and for 1 phase, 2-wire 120V system shall be "Red". Insulation colour of all neutral conductors shall be "White". Cable connectors in pole handholes shall be compression connectors with insulating covers.		
Fuses		Fuse holders in pole handholes shall be in-line break-away type rated 600V complete with 10 amp KTK fuse.		
Grounding	CSA C22.2 No.41	Ground rods shall be solid steel, 19mm Dia., 3.0m long, copper clad for full length.		

Material	Standards	Features	Manufacturer	Catalogue No.
2.0 Poles				
Standard Roadway Lighting Poles	CSA A14-M1979	<p>Direct Buried, Class “B” spun concrete, tapered round with natural concrete smooth mold finish, complete with handhole cover plate, nameplate and ground lug.</p> <p>Arterial Roads – 12.2m (40ft) Collector Roads – 10.7m (35ft) or 12.2m Local Roads – 7.5m (25ft) or 10.7m</p> <p>Base mounted galvanized octagonal steel poles as per OPSD-2415.010.</p> <p>Arterial Roads – 10.5m Collector Roads – 9.0m/10.5m Local Roads – 7.5m/9.0m</p>	StressCrete Sky Cast U.S.I.	
Poles for Walkways/Bikeways		<p>Base mounted contemporary pole with high tensile carbon steel shaft round (76mm) welded to top and bottom of anchor plate.</p> <p>Pole to be black semi-gloss powder coat finish complete with base cover assembled with stainless steel hardware.</p> <p>Photobutton light control recessed near top of pole.</p>		
Poles for Commercial Sites		<p>Poles shall be metal type square or round to suit the luminaire style and shall be base mounted. Poles shall have durable powder coat finish, colour to match the luminaire.</p> <p>Poles in parking areas shall be restricted to 30 ft. (9.1m) in height. Poles may be reduced in height down to 12 ft. (3.65m) level for pedestrian pathway applications.</p> <p>Wherever feasible, poles shall be located off the edge of pavement, behind barrier curbs (islands).</p> <p>Concrete bases in parking areas shall be protected by bollards or shall be raised to minimum 900mm above grade and be 760mm diameter.</p>		
3.0 Brackets				
Standard Roadway Lighting Brackets		<p>Tapered elliptical aluminium brackets as per OPSD 2420.01. The length of the bracket depends on offset from pavement and pole height.</p> <p>Arterial Roads – 2.4m (10ft) preferred, 3.0m maximum Collector Roads – 1.8m (8ft) preferred. Local Roads – 1.2m (6ft) preferred.</p>		
Walkways/Bikeways Brackets		<p>Single or double brackets with bend aluminium tubing with decorative aluminium rod, welded assembly and cast aluminium adaptor.</p>		

Material	Standards	Features	Manufacturer	Catalogue No.
4.0 Luminaires				
Standard Roadway Luminaires: High Pressure Sodium				
NOTE – HPS fixtures were allowed in the past. Currently all luminaires are to be LED type. This section is kept for general information only. Designer to consult the Town at the project start-up to confirm all design parameters.				
Arterial/Industrial Roads		<p>“Cobra Head” style, type II or III distribution pattern, medium cutoff, internally shielded with flat tempered glass lens and photocontrol receptacle.</p> <p>Lamp wattage to be long life 200W to 400W high pressure sodium.</p> <p>Luminaire housing to be die-cast aluminum with latch and standard grey polyester powder coat finish.</p> <p>Permanent type marking to be applied on underside of the luminaire housing for lamp wattage identification, (Yellow for HPS).</p> <p>Ballast to be C.W.I., 120 volt, 60Hz.</p>	<p>Cooper Lighting (OVF)</p> <p>AEL (series 315)</p> <p>GE (M-400A)</p>	
Collector Roads		<p>“Cobra Head” style, type II or III distribution pattern, medium cutoff, internally shielded with flat tempered glass lens and photocontrol receptacle.</p> <p>Lamp wattage to be long life 70W to 150W high pressure sodium.</p> <p>Luminaire housing to be die-cast aluminum, with latch and standard grey polyester powder coat finish.</p> <p>Permanent type marking to be applied on underside of the luminaire housing for lamp wattage identification, (Yellow for HPS).</p> <p>Ballast to be C.W.I., 120 volt, 60Hz.</p>	<p>Cooper Lighting (OVH)</p> <p>AEL (Series 315)</p> <p>GE (M-250R2)</p>	
Photo-controller		<p>Model TRS-1</p> <p>Photocontroller to have minimum surge protection of 40,000 amps and a minimum load rating of 1,000W/1,800 VA.</p> <p>Must have operating strength of 5,000 volts, and the photocell must be silicon sensor in glass and metal hermetic enclosure.</p> <p>Photocells shall be rated for a minimum of 100,000 operational hours.</p>	<p>FP Outdoor Lighting Controls/Sunrise Technologies</p>	

Material	Standards	Features	Manufacturer	Catalogue No.
Standard Roadway Luminaires				
Standard Roadway Luminaires: LED – Cobra Head		<p>Luminaire – Cobra Head style, type 2 or 3 distribution pattern, rugged die cast aluminum housing with surge and brown-out protection, LED drivers and electronic transfer switch. Temperature control by robust heat sink ensuring a minimum of 80,000 hours L70 at 40C operating ambient.</p> <p>Operating range from – 40 to + 50C with light engines meeting the dust and moisture rating of IP-66.</p> <p>Luminaire design to meet CSAC22.2 number 250 for 40C, wet location and to be ROHS compliant. Maximum total harmonic distortion to conform to ANSI C82.77: 2002.</p> <p>Solid state 120 volt 60 Hz electronic drivers with extended life to 100,000 hours minimum.</p> <p>LED colour temperature 4000 K nominal.</p> <p>All luminaires to be provided with a Dimming Module.</p> <p>5 year limited warranty on LED light engine, LED drivers and all non-electrical components.</p>	General Electric	<p>ERL1005B340A GRAYL</p> <p>ERL1007B340A GRAYL</p> <p>ERL1008B340A GRAYL</p> <p>ERL1010B340A GRAYL</p> <p>ERL1014B340A GRAYL</p>
Standard Roadway Luminaires: LED – Decorative		<p>Luminaire – Decorative lantern style, available in numerous distribution patterns to meet project specific requirements, rugged die cast aluminum housing with surge and brown-out protection, LED drivers.</p> <p>Operating range from – 40 to +40C, LED luminaire to meet IP65 rating. Luminaire design to meet CSA-C22.2 number 250 for 40C, wet location and to be ROHS compliant. Maximum total harmonic distortion to conform to ANSI C82.77: 2002.</p> <p>Solid state 120 volt 60 Hz electronic drivers with extended life to 100,000 hours minimum. Temperature control by robust heat sink ensuring a minimum of 100,000 hours L70 at 40C operating ambient</p> <p>LED colour temperature 4000 K nominal.</p> <p>All luminaires to be provided with a Dimming Module.</p> <p>Minimum 7 year limited warranty (10 year preferred) on LED light engine, LED drivers and all non-electrical components.</p>	<p>General Electric</p> <p>Phillips</p>	<p>K601D-S-P4NL-III-60(SSL)7030-120-4K-F4</p> <p>K601D-T-P4NL-III-40(SSL)7030-120-4K-F4</p> <p>K118R-B3AR-III-40(SSL)1036-120-K14-4K-F1</p> <p>MPTR-55W48LED4K-T-LE2-UNIV-RCD-NP</p>
Park Walkway/Bike way Luminaires		50W pulse start metal handle.	<p>General Electric</p> <p>Eaton</p>	<p>ERL1H05B340A GRAYL</p> <p>PRVA15DUNVT 2SABZ</p>

Material	Standards	Features	Manufacturer	Catalogue No.
Commercial Site Luminaires: Metal halide		<p>In general shall be of the “Architectural Site Lighting” style, contributing a cohesive look to the overall site lighting system.</p> <p>The architectural outdoor luminaires may be shoe-box or round type with good optics and full cut-off with optional house side shielding.</p> <p>Luminaires at lower mounting heights shall have a vandal proof lens. The luminaires shall be post top arm mounted suitable for 1A to 4C configurations and also be suitable for optional wall mount applications.</p> <p>Luminaire housings shall be diecast type with durable powder coat finish colour to match site architectural features.</p> <p>Lamp wattage for parking lot and site roadway lighting shall be in the 150 to 400 watt range, subject to application. Lamp wattage for pedestrian scale pathway and building zone lighting may be reduced to 70 watt metal halide.</p>		
5.0 Power Supply Management				
Pole Mounted Disconnects		<p>Pole mounted power supply disconnects shall be outdoor weatherproof type 240/120 V rated 100 amps with 60 amp 2 pole main breaker suitable for service entrance.</p>		
Pedestal Mounted Disconnects		<p>Pedestal mounted power supply disconnect shall be outdoor heavy gauge galvanized steel with lockable removable front cover complete with precast concrete base.</p> <p>Colour to be equipment green with powder coat finish.</p> <p>Interior power supply disconnect shall be 240/120 V rated 100 amps with 60 amp 2 pole main breaker suitable for service entrance. Branch breakers to be 30 amps 1 pole 120V.</p>	Pedestal Solutions Inc.	

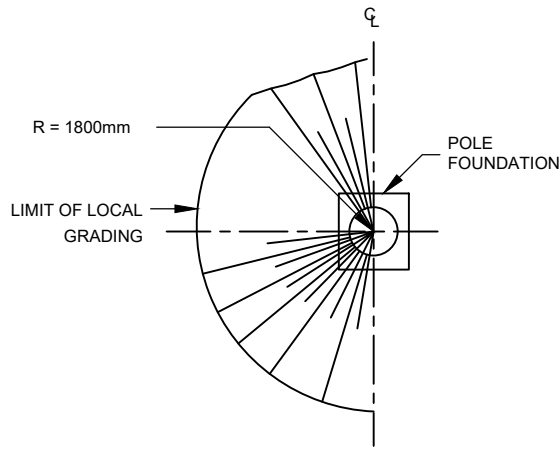

TYPICAL PLAN

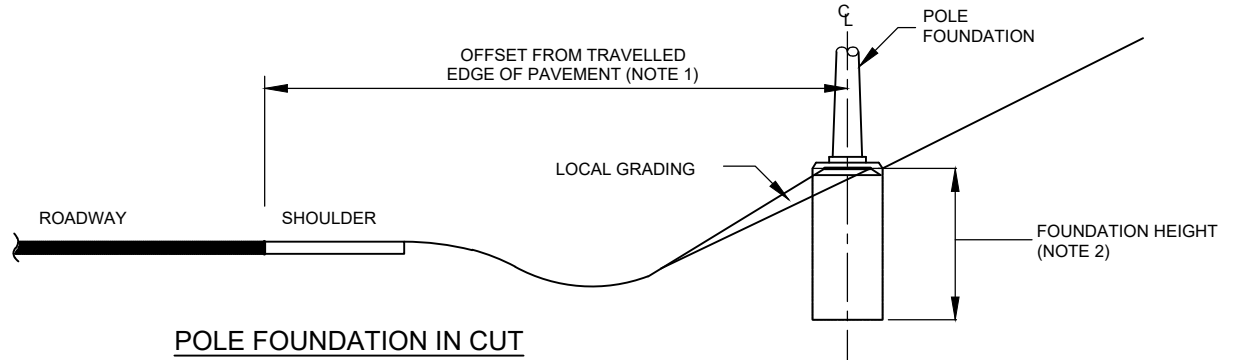

POLE FOUNDATION IN CUT

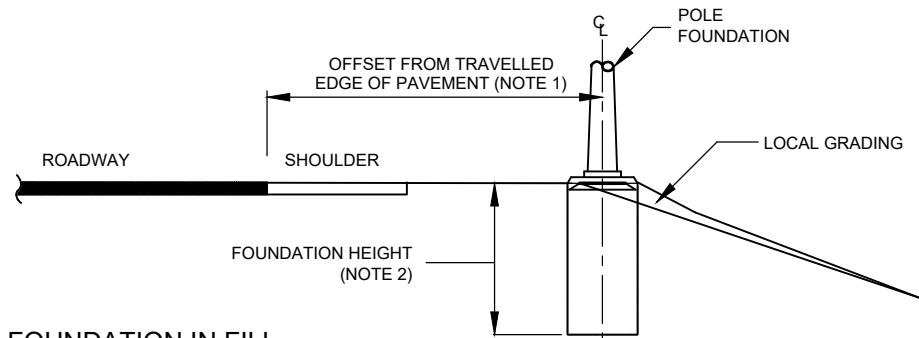

POLE FOUNDATION IN FILL

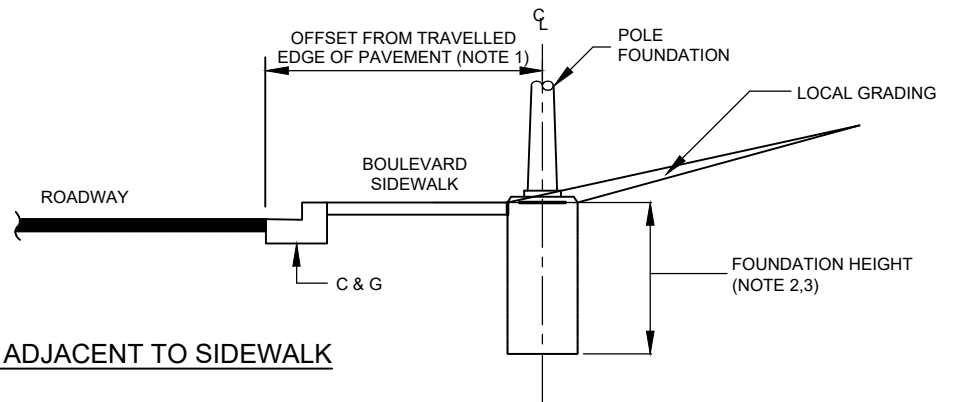

POLE FOUNDATION ADJACENT TO SIDEWALK

NOTES:

1. FOR OFFSET AND POLE TYPE, SEE CONTRACT DRAWINGS.
2. TOP OF FOUNDATION SHALL BE MEASURED FROM THE HIGHEST GRADE ELEVATION.
3. TOP OF FOUNDATION TO BE AT GRADE WITHIN 300mm OF SIDEWALK.
4. ALL DIMENSIONS ARE IN MILLIMETRES OR METRES UNLESS OTHERWISE SHOWN.



STANDARD DETAIL

LOCAL GRADING AT POLE FOUNDATIONS

APPROVED

MANAGER OF ENGINEERING DATE
 DIRECTOR OF OPERATIONS DATE

REVISION No. DATE: DEC 2021
 SCALE: N.T.S.

TSD-801